

**Valve/Cavity Compatibility**

For additional information see Technical Tips on pages BC2-BC3.

		VALVE			
		Parker	Waterman	FPS	CEC
CAVITY	Parker	X	X	X	X
	Waterman	X	X	X	X
	FPS	X	X	X	X
	CEC	X	X	X	X

**Performance Curve**  
**Pressure Drop vs. Flow**

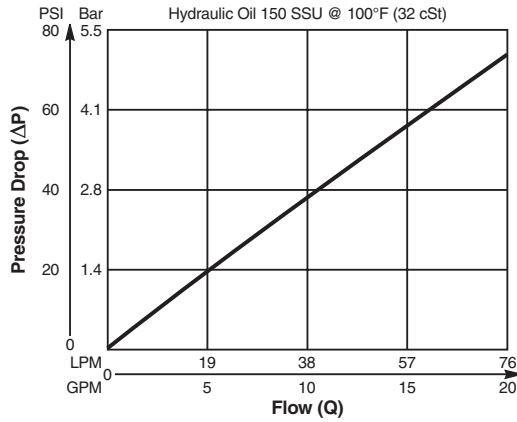

**Dimensions** Millimeters (Inches)

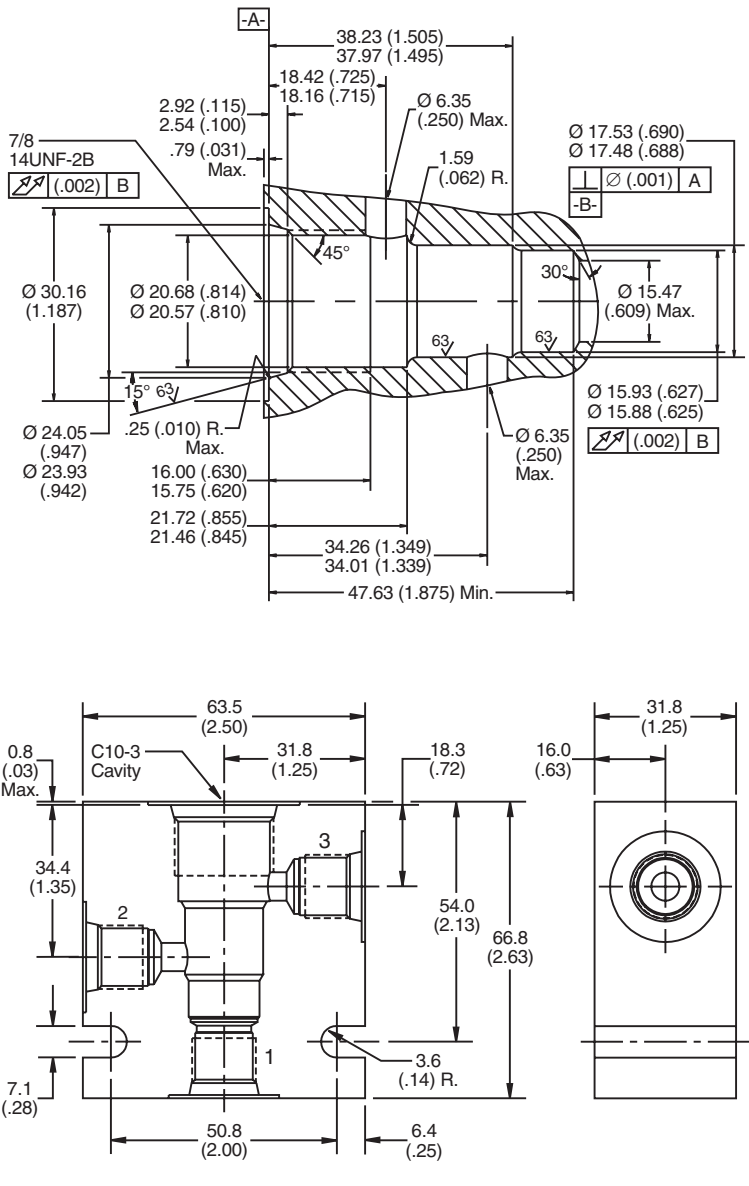

**Ordering Information**

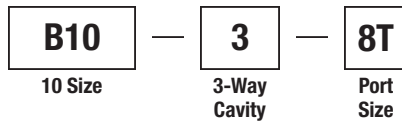

Code	Port Size
8T	SAE - 8/Steel (5000PSI)

**Weight:** .77 kg (1.7 lbs.)

- CV**  
Check Valves
- SH**  
Shuttle Valves
- LM**  
Load/Motor Controls
- FC**  
Flow Controls
- PC**  
Pressure Controls
- LE**  
Logic Elements
- DC**  
Directional Controls
- SV**  
Solenoid Valves
- PV**  
Proportional Valves
- CE**  
Coils & Electronics
- BC**  
Bodies & Cavities
- TD**  
Technical Data